

miniJET[®]: A New Type of Micropile

Dr. Donald A. Bruce¹, Jeffrey J. Bean², and Timothy J. Myers³

1.0 BACKGROUND

In U.S. practice (Reference 1), it is common to classify micropiles on the basis of their installation method, with particular reference to the grouting procedures. The original four types (A to D) have more recently been supplemented by Type E. As illustrated in Figure 1, the internal reinforcement of a Type E micropile is a continuously threaded, hollow bar. This bar is installed by injecting grout through the center as it is rotated to target depth. The fluid grout acts as the flushing medium during drilling, but also creates the annulus of grout around the bar which, when hard, transfers load from the steel to the soil. Type E micropiles are also known loosely as “self drilling micropiles” and their use has increased markedly throughout the world in the last decade in particular (Reference 2).

Classification Based on Grouting Method

- **Type A:** Gravity
- **Type B:** Pressure grouting through casing
- **Type C:** Single, global post grout
- **Type D:** Multiple, repeatable post grout
- **Type E:** Injection bore bars

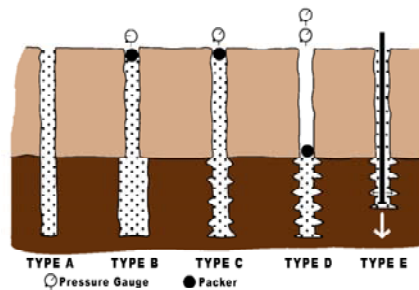

Figure 1. Classification of micropiles based on type of grouting (FHWA, 2000).

Conventional Type E piles have been injected at grout pressures which are moderate (typically up to 200 psi). As a consequence, the diameter of the grouted body is only marginally in excess of the bit diameter, and the thickness of the grouted annulus is rarely more than a few inches. Such micropiles can therefore be relied upon to provide good performance in tension, whereas their very high slenderness ratios restrict their capabilities to resist compressive or lateral loads.

¹ President, Geosystems, L.P., P.O. Box 237, Venetia, PA 15367, U.S.A., Phone: (724) 942-0570, Fax: (724) 942-1911, Email: dabruce@geosystemsbruce.com.

² Vice President of Operations, Layne GeoConstruction, 22537 Colemans Mill Road, Ruther Glen, VA 22546, U.S.A., Phone: (804) 448 8060, Fax: (804) 448 1771, Email: jjbean@laynegeo.com

³ District Manager, Layne GeoConstruction, 22537 Colemans Mill Road, Ruther Glen, VA 22546, U.S.A., Phone: (804) 448 8060, Fax: (804) 448 1771, Email: tjmyers@laynegeo.com.

This paper describes a new variant of the Type E pile, wherein the advantages of jet grouting technology are exploited to significantly increase the effective diameter of the pile as the bar is jetted into the soil, and to provide superior grout/soil skin friction potential. This development has been named by Layne GeoConstruction as miniJET[®].

2.0 SYSTEM DESCRIPTION

Many foundation remediations feature the construction of a jet grouted block which, depending on the structural loading requirements, may require steel reinforcement to help resist lateral and/or vertical stresses. Such steel reinforcements have traditionally been installed in holes drilled through the jet grouted block after it has reached a certain strength, and so often many days after the jet grouting has been completed. The time needed to sequence and conduct this reinforcement process can markedly impact the progress of such projects, especially when they involve restricted access such as in industrial facilities.

In contrast, miniJET[®] permits the jet grouting to be conducted and the columns to be internally reinforced in one operation. Figure 2 shows the components of the system, which are principally:

- Sacrificial drill bit with two or more nozzles to permit the grout to be ejected laterally (to jet grout the soil) and downwards (to facilitate penetration of the system). These drill bits can be modified as appropriate to match the site-specific soil conditions.
- Hollow, continuously-threaded steel bars of outside diameters 32-76 mm (Table 1). These can be provided in lengths of 1 to 6 m depending on specific project conditions.
- Steel couplers with special high pressure seals to prevent escape of grout during jetting.

These components are shown in Photograph 1. Photograph 2 shows a variation suitable for use as a permanent prestressed anchor (also patented). In this variant the bar is galvanized and protected/debonded over its free length by a polyethylene sheath. Regarding the installation equipment, the drilling rig is equipped with a special swivel at the drillhead while, in order to enhance the control and quality of the operation, automated drilling and grouting parameter instrumentation is provided in the drill rig. These data are relayed telemetrically in real time to the project's site office, as are the grouting data from the grout station. The grout station is typical of a conventional jet grouting installation, comprising an automated colloidal mixer, Tecniwell TWM20 or similar, which weighs batches bulk materials, an agitated storage tank, and a jet grouting pump, Tecniwell TW400 or similar.

3.0 CASE HISTORY

3.1 Background

Modifications to an existing industrial facility in Florida required extensive jet grouting to provide support for a number of excavations, and to provide deep foundations for support of a new structure. Due to the design requirement to provide significant tensile and lateral capacity, the jet grouted mass required internal, vertical reinforcement in many areas.

The specified structural design requirements for the jet grouted soil and the reinforcing steel were as follows:

- compression design load = 150 kips
- tension design load = 75 kips
- lateral design load = 20 kips
- minimum UCS jet grouted soil = 800 psi at 28 days
- maximum allowable compressive stress in jet grouted soil = $0.33f_c \equiv 264$ psi
- yield strength of steel = 86 ksi
- maximum allowable compressive stress in steel = 28 ksi
- maximum allowable tensile stress in steel = 42 ksi

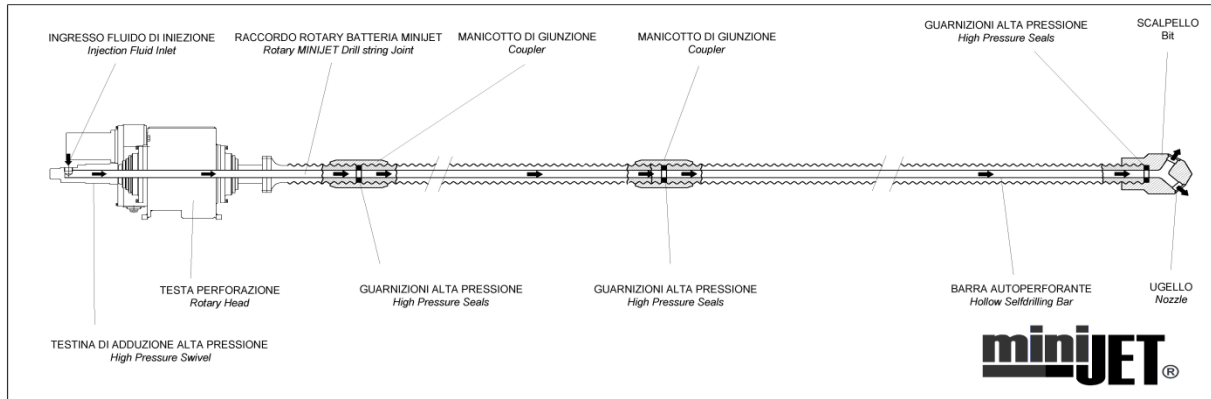

Figure 2. MiniJET® drill string assembly.

Technical Features	U.M.	Rm32/15	Rm38/16	Rm51/29	Rm76/48s
Outer Diameter	mm	32	38	51	76
Average Inner Diameter	mm	14	16	28	48
Ultimate Load	kN	415	540	840	1800
Yield Load	kN	350	450	700	1450
Suggested Working Load	kN	230	300	450	970
Weight	Kg/m	4.5	6.2	9.5	20.5
Delivery Lengths	m	1.0 m – 1.5 m – 2.0 m – 3.0 m – 4.0 m – 6.0 m			

Table 1. Sizes and properties of reinforcement.



miniJET® Hollow rebars



Rebar-rebar coupling

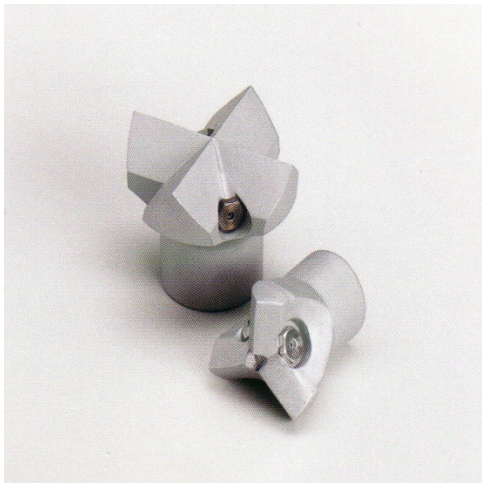

Drill bit with injection nozzles

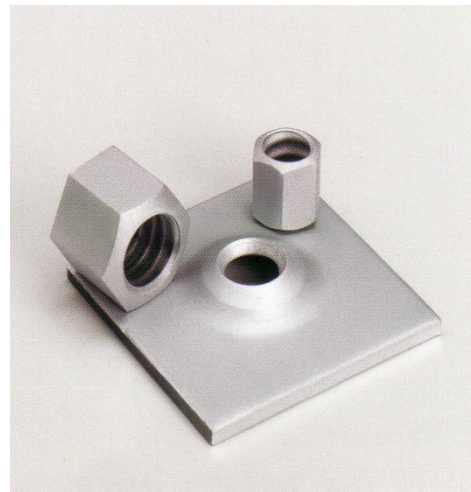

Nuts and anchoring plate

Photograph 1. MiniJET® components.

Layne proposed to install the support of excavation columns using “traditional” jet grout methods (one fluid), but to install the foundation elements with the miniJET® system. Further, a test program was designed to verify column diameter, strength and homogeneity and, by conducting load testing on miniJET® columns, confirm their structural and geotechnical performance and verify design assumptions. Allowable side friction values of 5 psi and 12 psi were used in the design for the upper 25 feet (medium sands) and lower 15 feet (dense sands) of soils, respectively. The jet grouted block was designed to bear on medium dense to dense sands.

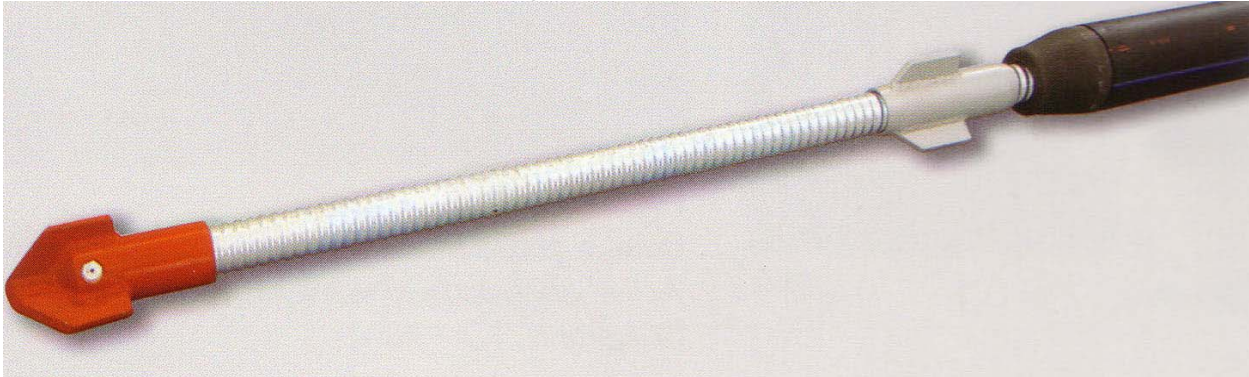
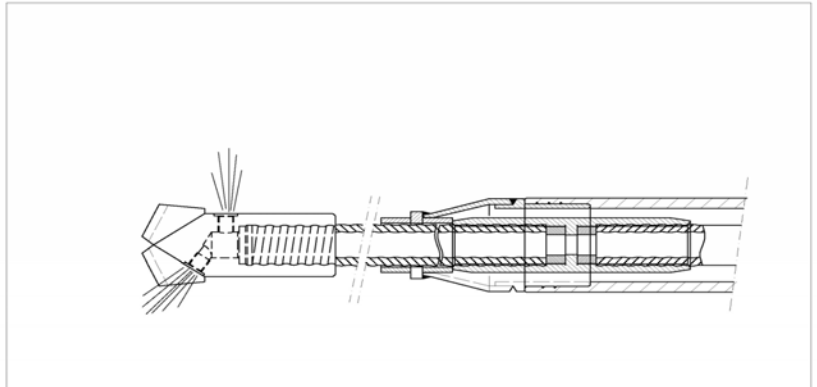

miniJET® PERMANENT ANCHOR
protected by galvanizing treatment and polyethylene casing (on the free zone)

Photograph 2. MiniJET® permanent anchor components.

3.2 Proposed Construction Details

The thread bar was the 51-29 type, supplied in lengths of 1, 3 and 6 m. As shown in [Table 1](#), this bar has a steel cross section of about 2.2 square inches and an ultimate load of 189 kips. Grout was anticipated to be a neat Type I/II mix of water:cement ratio 0.8. The columns would be installed by jetting from the top down. The drill bit had 3 nozzles, including two directed laterally to create the jet grouted column ([Photograph 3](#)). Upon reaching the target treatment depth, the bar would then be withdrawn to the elevation required to be reinforced. Jet grout parameters were selected to provide a nominal 2½-foot diameter column, and included an injection pressure of 400 bars.

3.3 The Foreseen Test Program

As shown in [Figure 3](#), two types of columns would be installed: Type A (25 feet) and Type B (35 feet). One of these 18 columns was to be installed with a 76 mm diameter bar for compression and tension testing for research purposes.



Photograph 3. MiniJET[®] system being prepared for insertion.

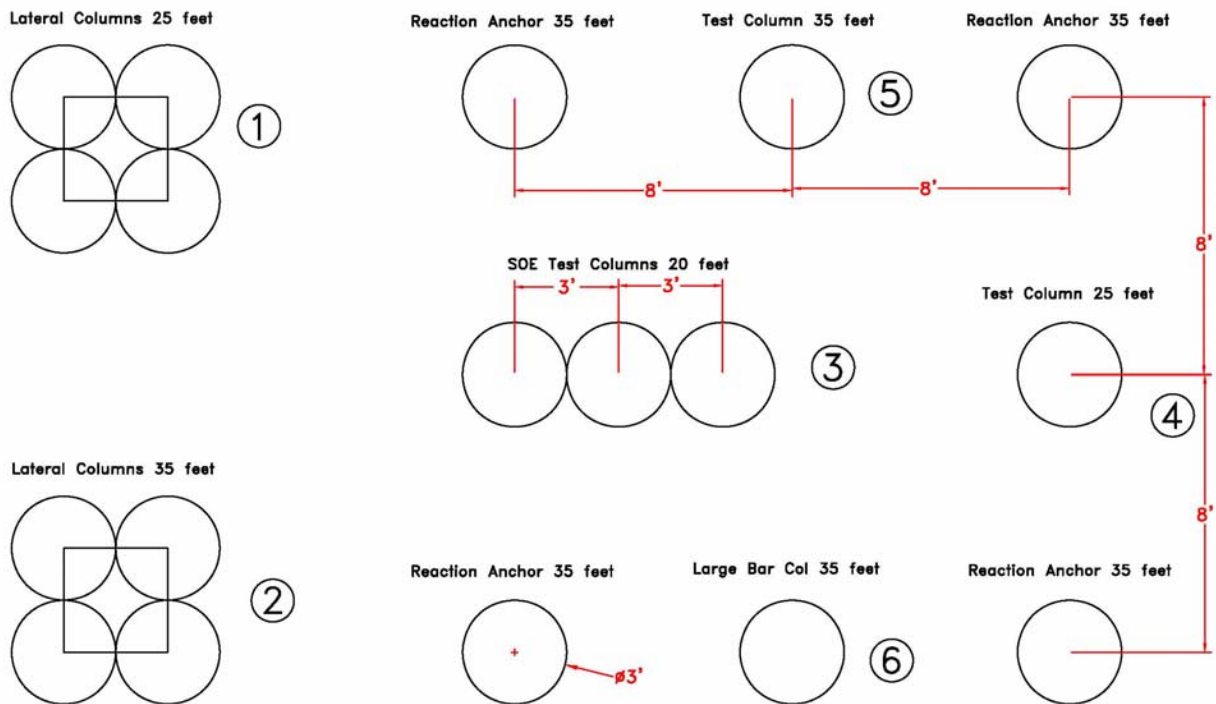

Figure 3. Test column layout, industrial facility, Florida.

The test piles can be summarized as follows:

TEST	NUMBER OF COLUMNS	DEPTH (FEET)	REINFORCEMENT	CONSTRUCTION	LOADING/ TESTING
1	4	25	2 with 51 mm bar	All miniJET [®]	Lateral
2	4	35	2 with 51 mm bar	All miniJET [®]	Lateral
3	3	20	None	Traditional	Geometry
4	1	25	51 mm bar	miniJET [®]	Tension and Compression
5	1	35	51 mm bar	miniJET [®]	Tension and Compression
6	1	35	76 mm bar	miniJET [®]	Tension and Compression

All 4 reaction anchors were to be installed with miniJET[®] and 76 mm bar.

The top of one of the 4-column groups was also to be exposed to observe geometry and homogeneity. Wet grab samples (3x6" moulds) were to be obtained on one of the two columns without reinforcement in each group: the other would be cored (3.25-inch sample) after testing, simply to provide some measure of correlation between the two methods. (Wet grab sampling is the standard quality assurance method in production.) Results to date from limited wet grab sampling are as follows:

DATE CAST	STRENGTH (PSI)			
	4 DAYS	5 DAYS	10 DAYS	14 DAYS
5/28/2010	1650		1710	1750
6/2/2010		1290	1520	1870

3.4 Test Program Results

Compression

Test data on Pile Test 4 (**CONFIRM**), are provided in Figure 4.

Salient data on this 25-foot deep element, with a measured diameter of 40 inches as exposed by excavation (Photograph 4), are as follows:

LOAD (KIPS)	TOTAL VERTICAL MOVEMENT (INCHES)
150	0.035
350	0.137
0	0.046

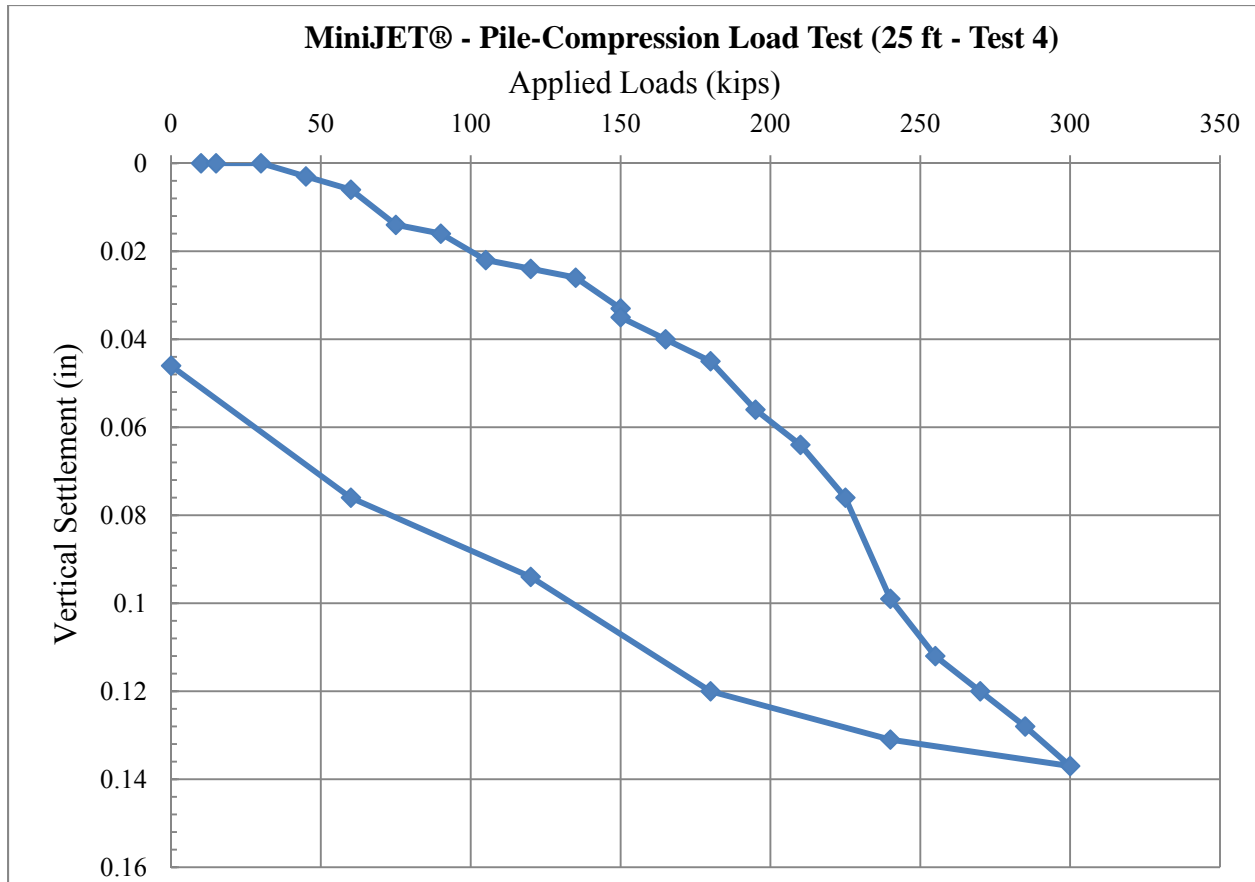

Figure 4. MiniJET® compression load test 4.



Photograph 4. Exposed miniJET® columns showing average 40-inch diameter.

Test borings in the vicinity confirmed the pile to have been installed in medium dense sand (N = 22). Based on previous experience, an ultimate grout/sand bond value of 15 psi is considered. This indicates that the test load was resisted by the upper 13 feet or so of the pile. Further, a strain gage fixed 2 feet from the bottom of the pile indicated practically no strain at the test load.

Tension

Figure 5 shows that the salient extension data are as follows:

LOAD (KIPS)	EXTENSION (INCHES)
75	0.161
150	0.517
0	0.236

The performance was linear and indicative of slight progressive debonding. At 150 kips, it may be calculated that the amount of apparent debonding of the bar was 9.6 feet.

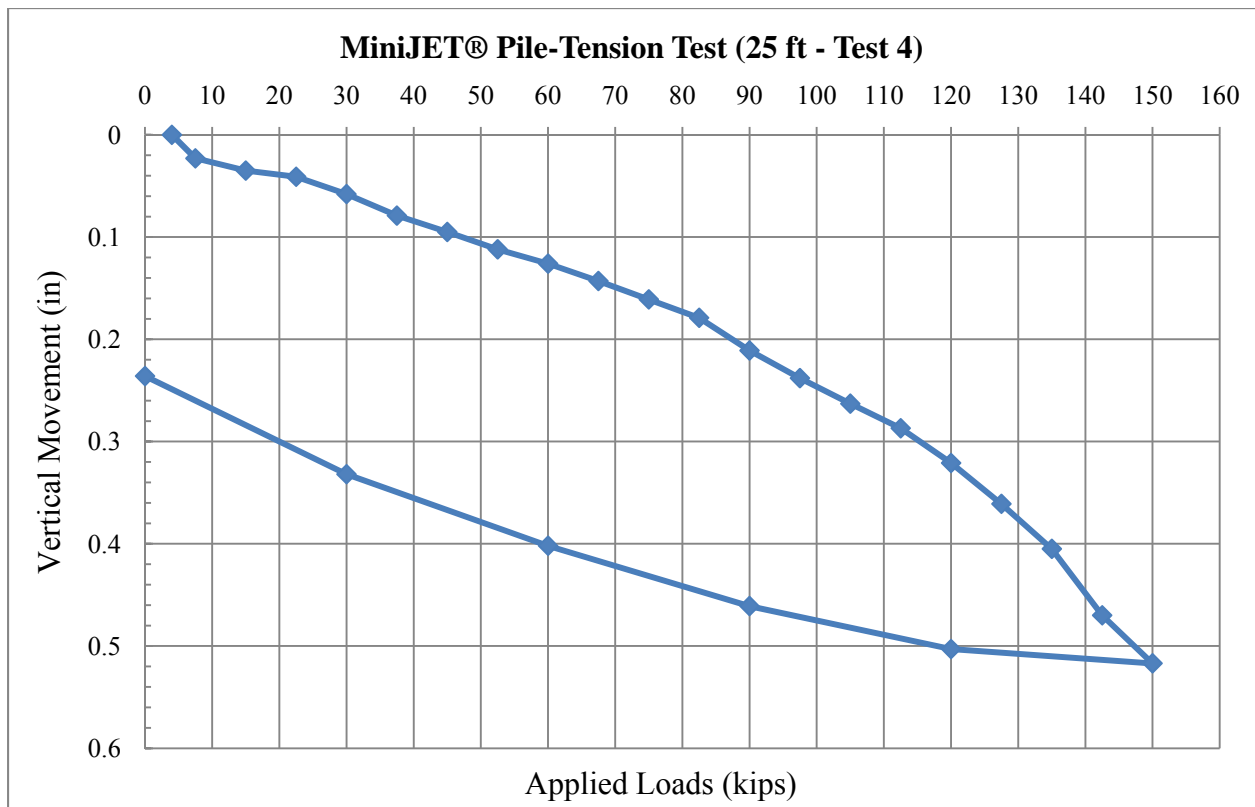

Figure 5. MiniJET® Tension Load Test 4.

Lateral

Data were obtained from 4 dial gages as follows:

GAGE	LOCATION (BELOW CAP) (INCHES)	MOVEMENT			
		AT 40 KIPS	AT 80 KIPS	RESIDUAL	ELASTIC
S1	25.75	0.038	0.137	0.113	0.024
S2	21.50	0.016	0.096	0.072	0.026
N3	20.25	0.010	0.034	0.009	0.025
N4	19.25	0.011	0.038	0.012	0.026

The jack reacted between the two column groups and was located 39.5 inches below the top of the pile cap. Note that a severe rain storm affected the readings of S1 and S2 in mid-test. However, as is shown above, the elastic deflection as measured at each gage at 80 kips (twice working load) was remarkably consistent.

Clearly the results of the axial and lateral tests were extremely impressive, with movements being very small and practically elastic, within the load range tested.

4.0 PRODUCTION

For the 19 different foundation/excavation locations, there were a total of 325 “conventional” support of excavation jet grout columns (totaling 6,175 lft) and 437 miniJET[®] columns (totaling 12,948 lft) approximately 90% of which were reinforced.

These elements ranged from 14-54 feet in depth, with most being 25 feet or 35 feet deep. The results from the test program permitted the overall length of columns to be reduced by over 4,400 lft, or about 30% of the originally designed scheme. The use of miniJET[®] also provided significant schedule and sequencing advantages.

REFERENCES

1. Federal Highway Administration (2000). “Micropile Design and Construction Guidelines: Implementation Manual” Publication No. FHWA-SA-97-070, June.
2. MacLean, D. (2010). “Typical Case History Using a Titan Micropile,” DFI-ADSC Micropiles Seminar: Industry Trends and Developments, Toronto, ON, Canada, Deep Foundations Institute, April 8.